

**: B56Hx60/1P**

SSP : B56N-W

		1	2
		<b>Propylene Glycol - Water (20.0 mass%)</b>	
		<b>Water</b>	
		T	
		<b>95.00</b>	
		<b>45.0</b>	
		<b>55.0</b>	
		kg/s	
		2.345	
		2.272	
		kPa	
		10.2 (30.00)	
		3.58 (30.00)	
		2.00	
		2.00	
		1	
		2	
		m <sup>2</sup>	
		6.61	
		kW/m <sup>2</sup>	
		14.4	
		K	
		5.0	
		W/m <sup>2</sup> ,°C	
		2870	
		kPa	
		10.2	
		3.58	
		kPa	
		0.175	
		0.167	
		mm	
		70.0/70.0	
		70.0/70.0	
		29	
		30	
		60	
		9	
		m <sup>2</sup> ,°C/kW	
		0.029	
		808.1	
		1163	
		m/s	
		0.607/0.607	
		0.598/0.598	
		m/s	
		0.161	
		0.153	
		kPa	
		0.0245	
		8.34e-3	
		°C	
		52.7	
		52.3	
		K	
		0.4	
		°C	
		47.7/57.7	
		47.3/57.3	

i This is an asymmetric model. Side 1 refers to circuit F1-F3. Side 2 refers to circuit F2-F4.

		1	2
		°C	
		55.0	
		50.0	
		cP	
		0.841	
		0.547	
		kg/m <sup>3</sup>	
		1003	
		988.1	
		kJ/kg,°C	
		4.051	
		4.181	
		W/m,°C	
		0.5258	
		0.6436	
		W/m <sup>2</sup> ,°C	
		6860	
		6840	
		1	
		2	
		kg	
		34.66 - 38.09	
		kg	
		49.47 - 52.91	
		dm <sup>3</sup>	
		6.09	
		dm <sup>3</sup>	
		8.91	
		mm	
		70	
		mm	
		70	
		mm	
		70	



		1	2
F4/P4	mm	70	

\*

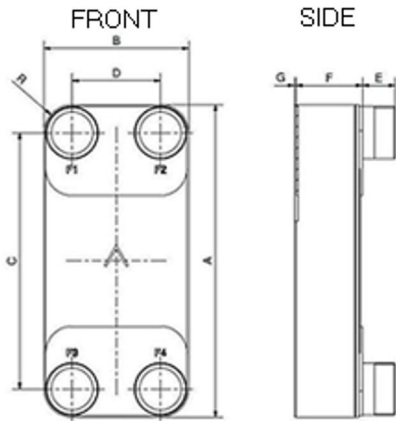

A	mm	525 ±2
B	mm	243 ±1
C	mm	430 ±1
D	mm	148 ±1
E	mm	54 (opt. 81) ±1
F	mm	160.4 +0.5%/-1.5%
G*	mm	2.5 - 3 ±1
R	mm	48

\*

SWEP.

	Unit	Value
Sweden - Landskrona	kg CO <sub>2</sub> e	178.5 - 196.2
USA - Tulsa	kg CO <sub>2</sub> e	187.2 - 205.7
Slovakia - Košice	kg CO <sub>2</sub> e	202.9 - 223.1
Malaysia - Kuala Lumpur	kg CO <sub>2</sub> e	282.6 - 310.6
China - Suzhou	kg CO <sub>2</sub> e	484.8 - 532.9

**Legal notice:**

By using the SSP/DThermX software the Licensee confirms that the input data is not subject to export control laws including ITAR (International Traffic in Arms Regulations). Licensee further agrees and confirms that the configured products are not subject to export control laws including ITAR and do not qualify as "specially designed" for export control purposes. If you would like to discuss configuration of export controlled products including ITAR-qualifying products, or if your data is export controlled, please reach out to your SWEP representative or email info@swepgroup.com.

**Disclaimer:**

Data used in this calculation is subject to change without notice. SWEP strives to use "best practice" for the calculations leading to the above results. Calculation is intended to show thermal and hydraulic performance, no consideration has been taken to mechanical strength of the product. Product restrictions - such as pressure, temperatures and corrosion resistance- can be found in SWEP product sheets and other technical documentation. SWEP may have patents, trademarks, copyrights or other intellectual property rights covering subject matter in this document. Except as expressly provided in any written license agreement from SWEP, the furnishing of this document does not give you any license to these patents, trademarks, copyrights, or other intellectual property. To the maximum extent permitted by applicable law, the software, the calculations and the results are provided without warranties of any kind, whether express or implied. No advice or information obtained through use of the software (including information provided in the results), will create any warranty not expressly stated in the applicable license terms. Without limiting the foregoing, SWEP does not warrant that the content (including the calculations and the results) is accurate, reliable or correct. SWEP does not warrant that any system comprising heat exchanger and other components, installed on the basis of calculations in this software, will meet your requirements or function to your satisfaction or expectations.

